

AITHER

Monos 9 in Hanging Sconce

Installation Instructions

INSTALLATION MUST BE PERFORMED BY A QUALIFIED ELECTRICIAN
PLEASE USE THE FOLLOWING DIAGRAM AND STEPS FOR INSTALLATION

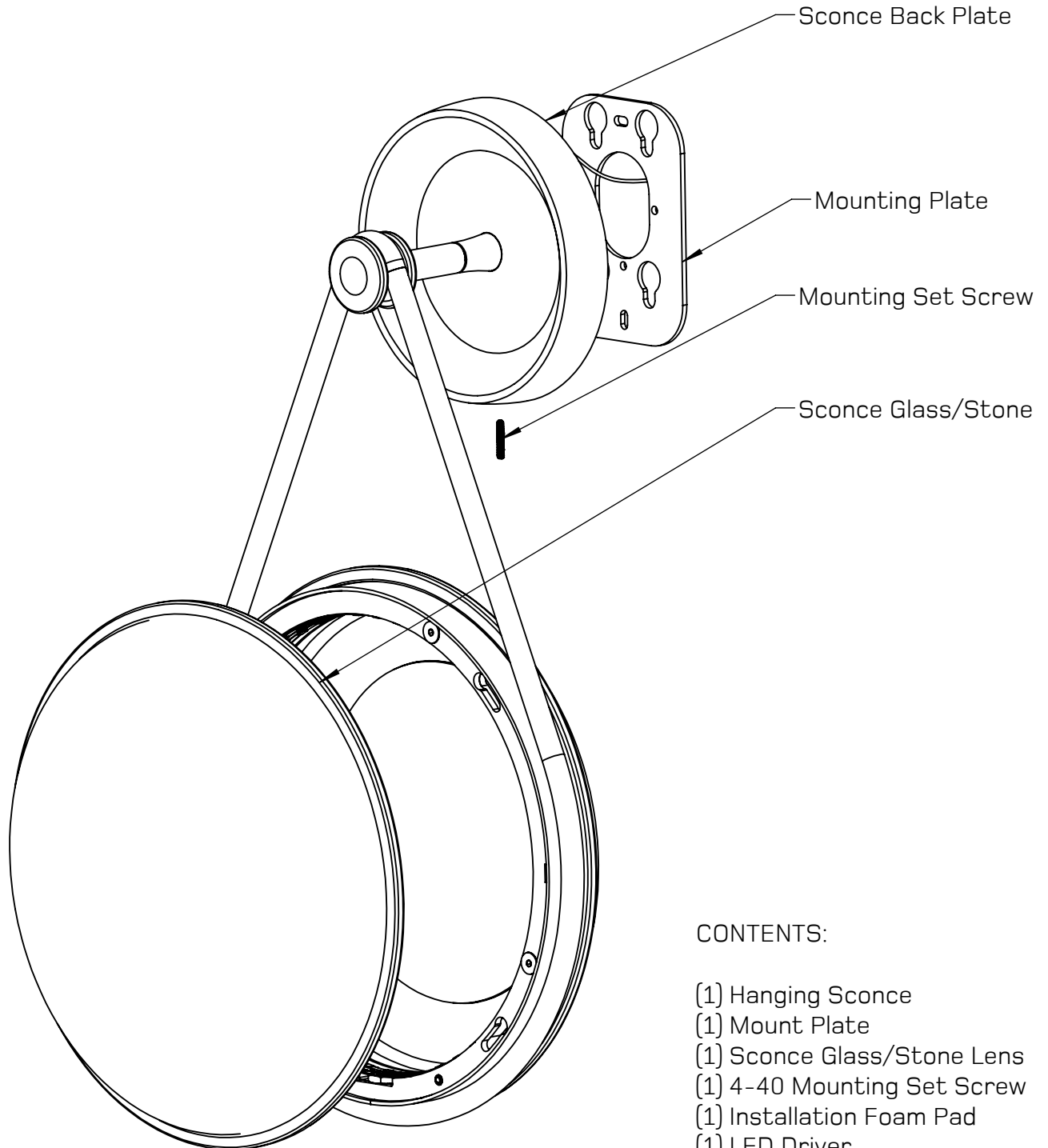

CONTENTS:

- (1) Hanging Sconce
- (1) Mount Plate
- (1) Sconce Glass/Stone Lens
- (1) 4-40 Mounting Set Screw
- (1) Installation Foam Pad
- (1) LED Driver
- (1) 0.050 Hex Key
- (7) Blue Wire Nuts
- (2) 6-32 PHPMS

AITHER

Monos 9 in Hanging Sconce

Installation Instructions

INSTALLATION MUST BE PERFORMED BY A QUALIFIED ELECTRICIAN
PLEASE USE THE FOLLOWING DIAGRAM AND STEPS FOR INSTALLATION

INSTALLATION INSTRUCTIONS:

1. Make sure all power is shut off to the j-box (Junction Box) where the fixture will be installed.
2. Make electrical connections from A/C power to A/C input wires on the high voltage side of the LED driver. Secure LED driver in the j-box.
3. Secure mounting plate to the wall or j-box with appropriate hardware and/or anchors per installation requirements.
NOTE: Mounting requirements and hardware to be determined and provided by installer
4. Remove packaging from sconce fixture and place on installation foam pad with sconce back plate in cutout in the foam pad. See Figure A-1.
NOTE: DO NOT allow fixture to rest on any surface without the installation foam pad support.
5. Install glass/stone to sconce by aligning and inserting locking stand-offs with with key slots in fixture body. Turn glass/stone clockwise until fully seated. See Figure A-2 & A-3.
NOTE: Ensure glass/stone is locked into fixture.
Lightly try to turn the glass/stone counter-clockwise;
glass/stone should not rattle or be able to be removed.
6. Carefully raise fixture out from the foam pad up to the installation location. Support both the back plate and the stone/glass when lifting or moving sconce.
7. Make electrical connections from the fixture wires to the output wires on the low voltage side of the LED driver in the j-box. Use leads labeled for low voltage use. See Wiring Diagram. Ground fixture using pre-installed ground wire. Secure all excess wires in the j-box.
NOTE: Red (+) to Red (+); Black (-) to Black/Blue (-)
8. Install fixture to mounting plate by aligning & inserting the locking stand-offs with the key slots in the mounting plate. Once inserted, slide down to secure. Ensure stand-offs on back plate are fully seated in key slots on mounting plate. See Figure A-4.
9. Secure fixture to mounting plate by tightening mounting set screw with the provided 0.050 Hex Key.
10. Minor adjustments can be made by hand to ensure fixture is hanging straight. Lightly push hanging body in desired position. DO NOT FORCE.

AITHER

Monos 9 in Hanging Sconce

Installation Instructions

INSTALLATION MUST BE PERFORMED BY A QUALIFIED ELECTRICIAN
PLEASE USE THE FOLLOWING DIAGRAM AND STEPS FOR INSTALLATION

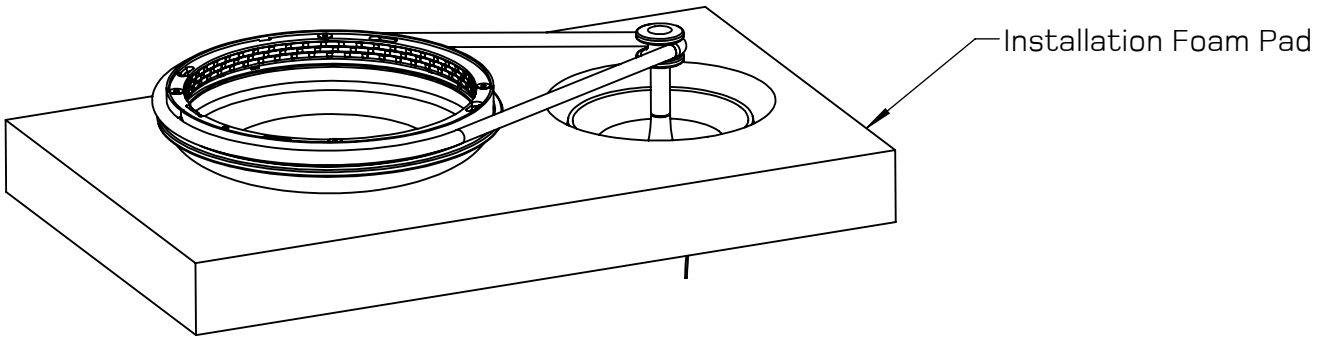

FIGURE A-1

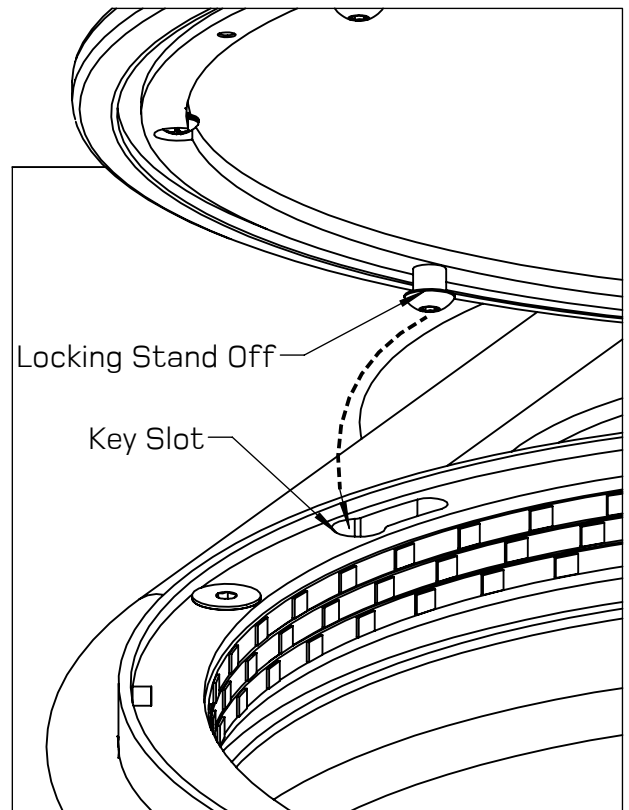

FIGURE A-2

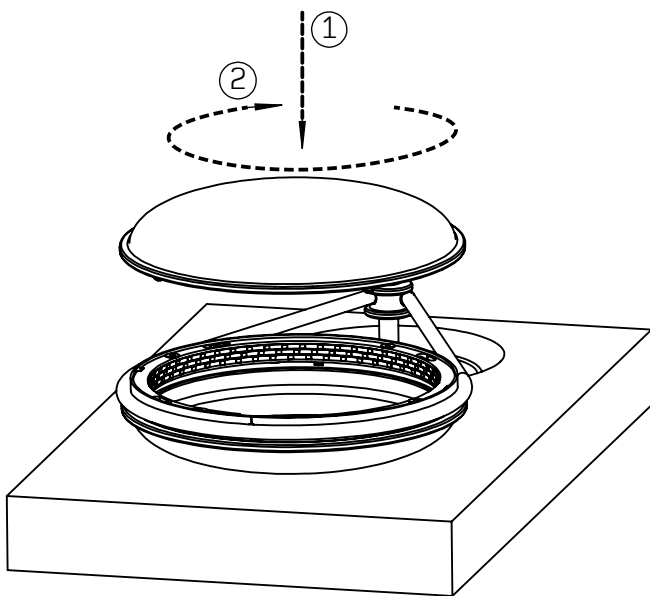

FIGURE A-3

AITHER

Monos 9 in Hanging Sconce

Installation Instructions

INSTALLATION MUST BE PERFORMED BY A QUALIFIED ELECTRICIAN
PLEASE USE THE FOLLOWING DIAGRAM AND STEPS FOR INSTALLATION

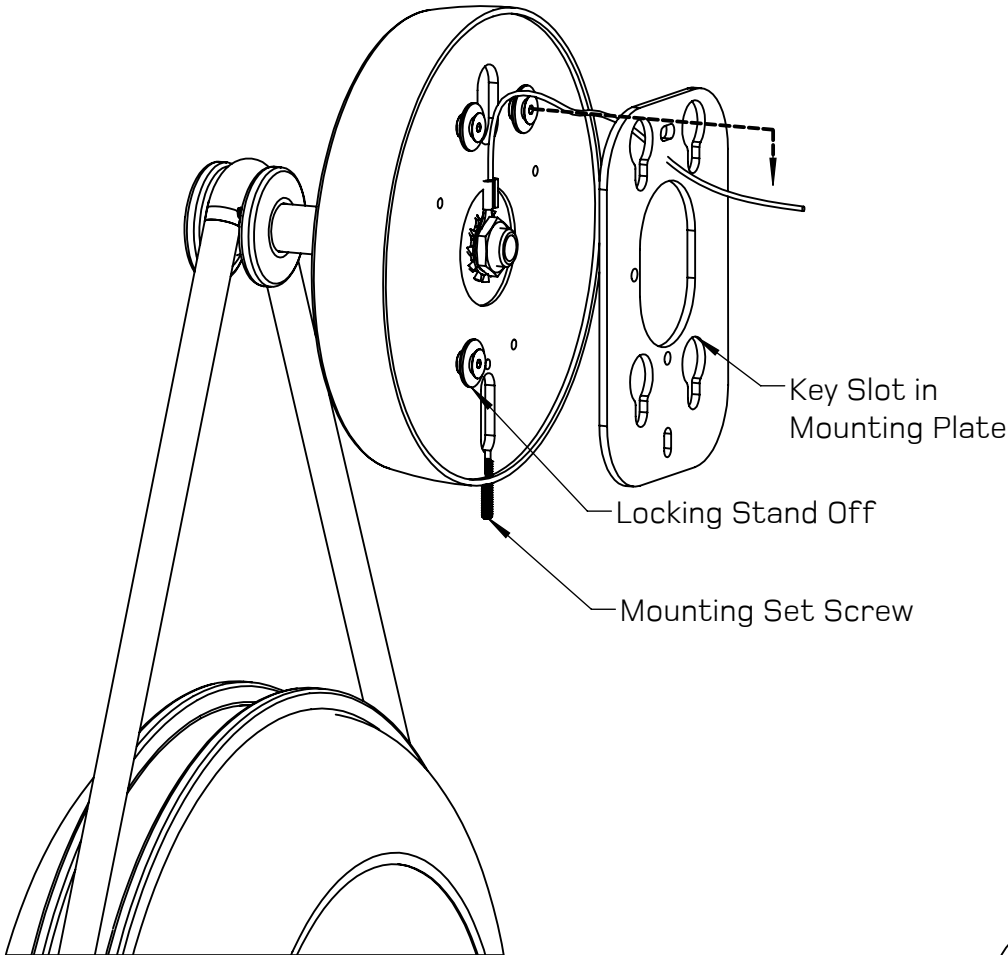

FIGURE A-4

WIRING DIAGRAM

