

AITHER

Monos 9 in Button Sconce

Installation Instructions

INSTALLATION MUST BE PERFORMED BY A QUALIFIED ELECTRICIAN
PLEASE USE THE FOLLOWING DIAGRAM AND STEPS FOR INSTALLATION

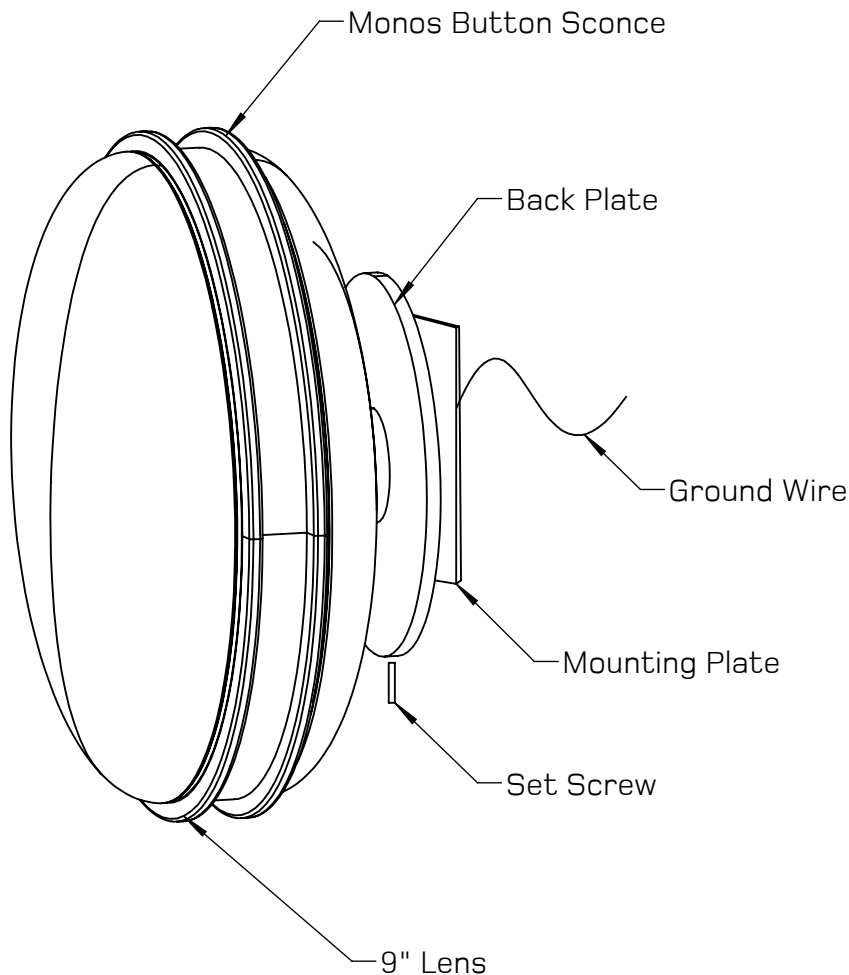

Contents:

- (1) Monos 9" Button Sconce
- (1) 9" Lens, Order Specific
- (1) Mounting plate with ground wire
- (2) 6-32 FHPMS
- (1) LED Driver
- (7) Blue Wire Nuts
- (1) .05 Hex Key
- (1) Pair White Gloves

AITHER

Monos 9 in Button Sconce

Installation Instructions

INSTALLATION MUST BE PERFORMED BY A QUALIFIED ELECTRICIAN
PLEASE USE THE FOLLOWING DIAGRAM AND STEPS FOR INSTALLATION

INSTALLATION INSTRUCTIONS:

1. Make sure all power is shut off to the j-box (Junction Box) where the fixture will be installed.
2. Make electrical connections from A/C power to A/C input wires on the high voltage side of the LED driver. If using 0-10V Dimming connect purple and gray wires from driver to purple and gray 0-10V dimming wires in junction box. If not using 0-10V dimming cap wires.
3. Secure mounting plate to the wall or j-box with appropriate hardware and/or anchors per installation requirements. Feed low voltage wires from driver through center hole in junction box.

NOTE: Mounting requirements and hardware to be determined and provided by installer

4. Make electrical connections from the fixture wires to the output wires on the low voltage side of the LED driver in the j-box. Use leads labeled for low voltage use. See Wiring Diagram. Ground fixture using pre-installed ground wire. Secure all excess wires in the j-box.

NOTE: Red (+) to Red (+); Black (-) to Black/Blue (-)

5. Install fixture to mounting plate by aligning & inserting stand-offs with the key slots. Once inserted, slide down to secure. Ensure stand-offs on back plate are fully seated in key slots on mounting plate. See Figure A-4.
6. Secure fixture to mounting plate by tightening mounting set screw with the provided 0.050 Hex Key.
7. Install glass/stone to sconce by aligning and inserting locking stand-offs with with key slots in fixture body. Turn glass/stone clockwise until fully seated.

NOTE: Ensure glass/stone is locked into fixture.

Lightly try to turn the glass/stone counter-clockwise;
glass/stone should not rattle or be able to be removed.

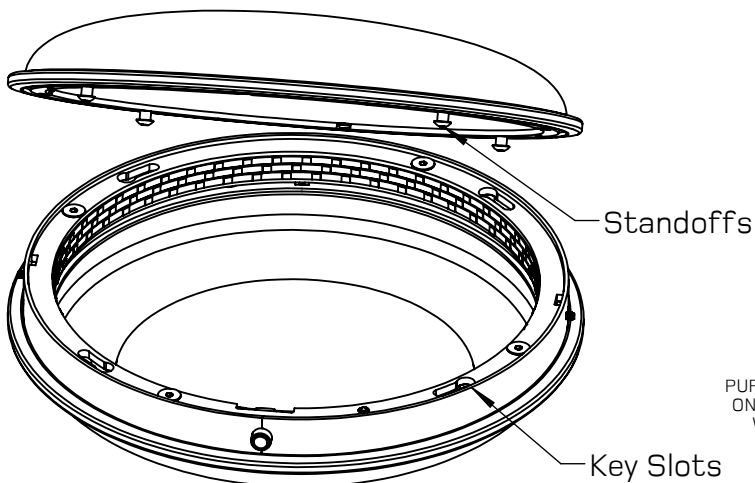

WIRING DIAGRAM

