



A I T H E R

MONOS HANGING SCENCE

MONOS HANGING SCONCE CREATOR DOUGLAS LEVINE



DIMENSIONS

Width 9.2 in (23.4 cm)
Depth 4.8 in (12.2 cm)
Height 16.6 in (42.1 cm)

BACKPLATE

Diameter 5.0 in (12.7 cm)
Height 0.9 in (2.29 cm)

WEIGHT

15 pounds (6.8 kg)

ELECTRICAL

Integrated LED, Dimmable Driver, 120V or 220V,
650 Lm, 2700K, 90+ CRI
UL Listed, cUL Listed, CE Listed, IP41

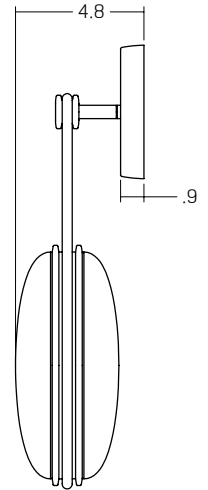
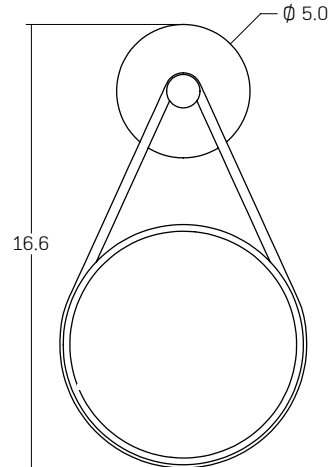

INSPIRATION

Singular, but far from alone, Monos offers a beautiful illusion, in which glass and metal merge seamlessly, creating a monochromatic effect. Like a stormy sea, smoked glass fades to clear. Metal plates gently curve, beckoning you to come closer. Interchangeable glass and stone lenses allow for the ultimate in customization. Available in multiple sconce, pendant, and chandelier designs, all in six finishes.

LENS OPTIONS



FINISH OPTIONS

